

REVISION	RECORD	Date
V1.0	First release	2024-08-15

Front

Side

Back

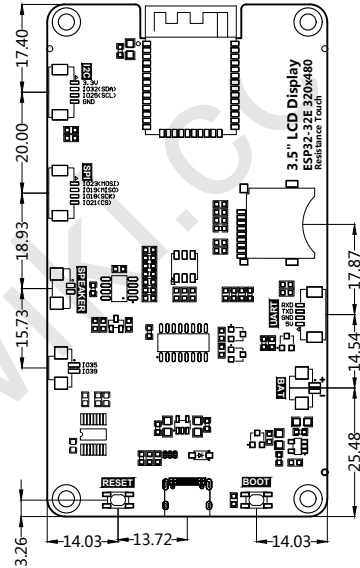
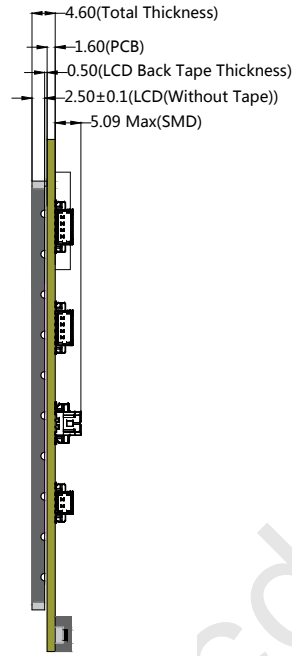
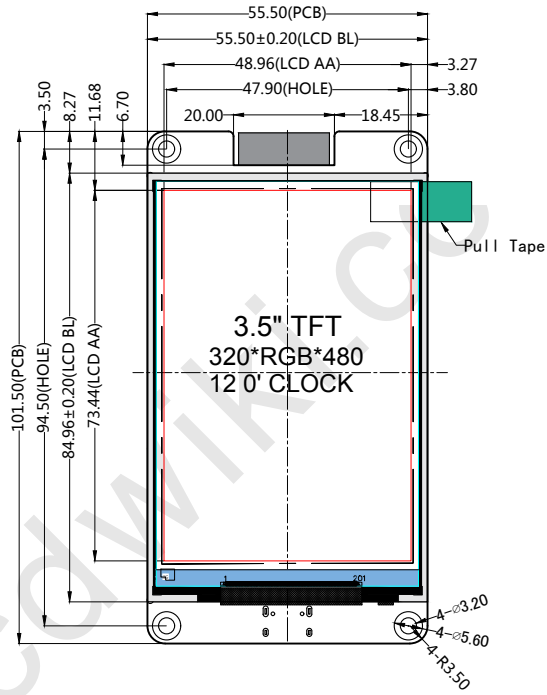

NOTES:

1. DISPLAY MODULE: 3.5" ESP32-32E DISPLAY
2. VIEWING DIRECTION: 12 O' CLOCK (TN TFT)
3. DRIVE IC: ST7796
4. POLARIZER MODE: TRANSMISSIVE/POSITIVE
5. RESOLUTION: 320*RGB*480
6. INTERFACE: SPI_4-Line (CONNECT TO ESP32)
7. UNMARKER TOLERANCE: ±0.2
8. OPERATING TEMP: -10°C ~ +60°C

<p style="text-align: center;">深圳市全动电子技术有限公司 ShenZhen QDtech electronic technology Co.,LTD.</p>					DRG DATE	2024-08-15	
					DRAWING	Joan	
TITLE.	LCM OUTLINE	REV.	UNIT	SIZE	(3)	CHECK	Green
SKU.	E32N35T	V1.0	mm	A4		APPROVE	Rose